

RTRD

5-Stage control unit with motor protection and connection for room thermostat



5-Stage control unit

Three-phase, 5-speed controller with mains contactor and monitor light for speed regulation with transformer of voltage controlled motors / fans. With the step switch, which is built into the controller, five different speeds can be adjusted on the connected motor / fan. Thus switch step 1 corresponds to the lowest, respectively switch step 5 corresponds to the highest speed.

Room thermostat connection: When connecting room thermostat dependent on the adjusted temperature at the thermostat the motor is switched off over the controller.

The controller's control circuit is protected by a fuse of 2A.

Motor protection

On exceeding the maximum permissible winding temperature of the motor/fan, the thermal contacts, which are embedded in the motor winding, open. The mains contactor, which is incorporated in the controller, drops and disconnects the motor/fan from the mains power supply. After the cause of the interruption has been remedied, restarting is only possible at the 0-position on the 5-step switch.

After power failure

Switch on again is only possible after a first switch to the 0-step.

Design

RTRD 1.2 / RTRD 2.5 / RTRD 3 / RTRD 3.8

Enclosure with aluminium die cast base and light grey plastic lid in protection class IP54.

RTRD 5

Plastic coated white sheet steel in enclosure in protection class IP54.

RTRD 7 / RTRD 10

Plastic coated grey sheet steel in enclosure in protection class IP54.

Technical Data:

Dimensions:

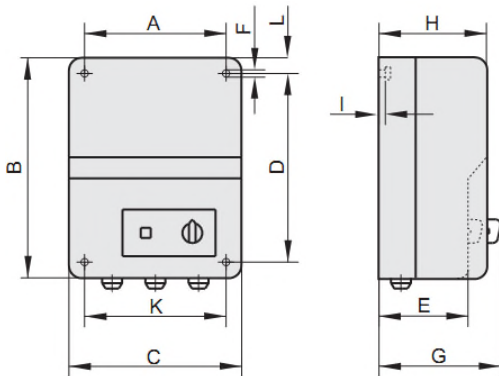

Type	Art.-No.	max. current [A]	Weight [kg]	Protection class	A	B	C	D	E	F	G	H	I	K	L
RTRD 1.2	H90-01200	1.2	6.0	IP 54	180	290	230	253	120	7	145	136	3.5	205	10
RTRD 2.5	H90-02500	2.5	10.5	IP 54	180	290	230	253	120	7	145	136	3.5	205	10
RTRD 3.0	H90-03003	3.0	12.0	IP 54	180	290	230	253	120	7	145	136	3.5	205	10
RTRD 3.8	H90-03800	3.8	15.0	IP 54	180	290	230	253	120	7	145	136	3.5	205	10
RTRD 5.0	H90-05005	5.0	15.0	IP 54	216	315	245	285	---	7	158	133	---	216	15
RTRD 7.0	H90-07003	7.0	26.0	IP 54	315	410	380	345	---	7	173	155	---	315	33
RTRD 10	H90-10002	10	32.0	IP 54	315	410	380	345	---	7	173	155	---	315	33

Wiring Diagram:

01.128

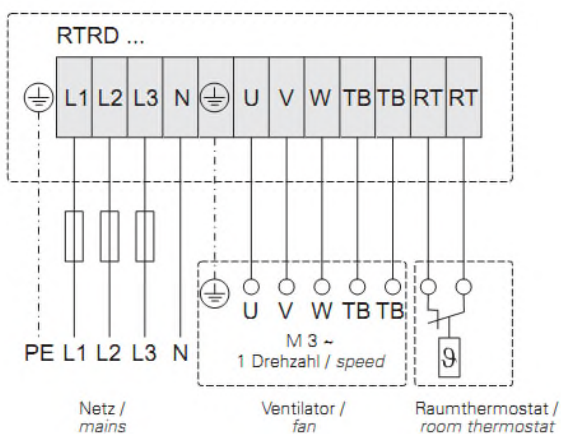

Scope of Delivery:

- 5-Stage control unit (RTRD)
- Documentation

Voltage Specification:

Current type	Input	Level	Voltage
Three phase	3~400V / 50Hz	1	140V
		2	180V
		3	230V
		4	280V
		5	400V